

Programmable Relay and Servo Board

EVILUSIONS

Programmable Relay and Servo Board



The Evilusions Programmable Relay and Servo Control board allows you to program a sequence of on/off relay closures and the independent movement of a servo motor. The program can last up to 4 minutes in length. The program, once entered, can be started by pressing a Play switch or connecting to a dry contact switch closure for remote triggering.

Details:

As mentioned above, The Evilusions Programmable Relay and Servo Control board allows you to program the on/off sequence of a 10 Amp relay as well as the positioning of a servo motor. The relay and servo can be programmed to operate completely independent of each other and programs can last up to 4 minutes in length. Other features include:

- Indicator light for Relay.
- Relay and Servo actuate in real time while program is being entered.
- Ability to remotely trigger program.
- Program remains in memory even with power removed.
- Program loop function

Operation:

To program the relay, momentarily press the first pushbutton. You will see a yellow LED light indicating that the program for the relay is being recorded. Press the Key / Play pushbutton to actuate the relay. When you are done entering your program for the relay, press the Relay Program pushbutton again. The yellow LED will go out indicating that the program sequence is over. To program the Servo, Press the Servo Program pushbutton and a yellow LED will light indicating that it is recording. Turn the on-board potentiometer to control the position of the servo. As you turn the pot, the servo will mimic the movement in real time. The program for the relay will also start playing. This allows you to synchronize the relay to the servo movement. When you are done recording that channel, press the programming pushbutton for that servo again and the yellow LED for the servo will go out. Your program for each channel can last up to 4 minutes. If you exceed the 4 minute time period, the board will automatically terminate the program and turn off the yellow LED. If the length of the servo program is shorter than the length of the relay program, then the relay program will continue to play until it finishes. Once both programs have been stored, you can play everything back by pressing the Key / Play pushbutton – a green Play LED will light while the program is playing. Alternatively, you can hook a dry contact closure to the terminal block located next to the Play pushbutton and every time it is activated, the board will play back both programs. If you want to continuously loop the stored programs, switch the Loop Switch to Loop and the program will repeat over and over once triggered.

Programmable Relay and Servo Board

You can re-record a program on either channel by simply repeating the programming process for that channel – it will overwrite whatever was previously recorded on that channel. To completely erase a program for a channel, just press the programming pushbutton for that channel, let it record for a second or two (without operating the potentiometer). Press the program button again to stop programming and the channel is now empty. Essentially, what you have done is record a 1-2 second program of nothing. This has no effect on the program stored in the other channel.

The board has a voltage regulator that allows you to power it with DC voltages of between 7.5 V and 24V. You must make sure that the power supply is capable of providing enough current to power the board and the servo (1A max) - otherwise, it could cause the board to reset.

Board Layout:

Below is a diagram showing component placement.

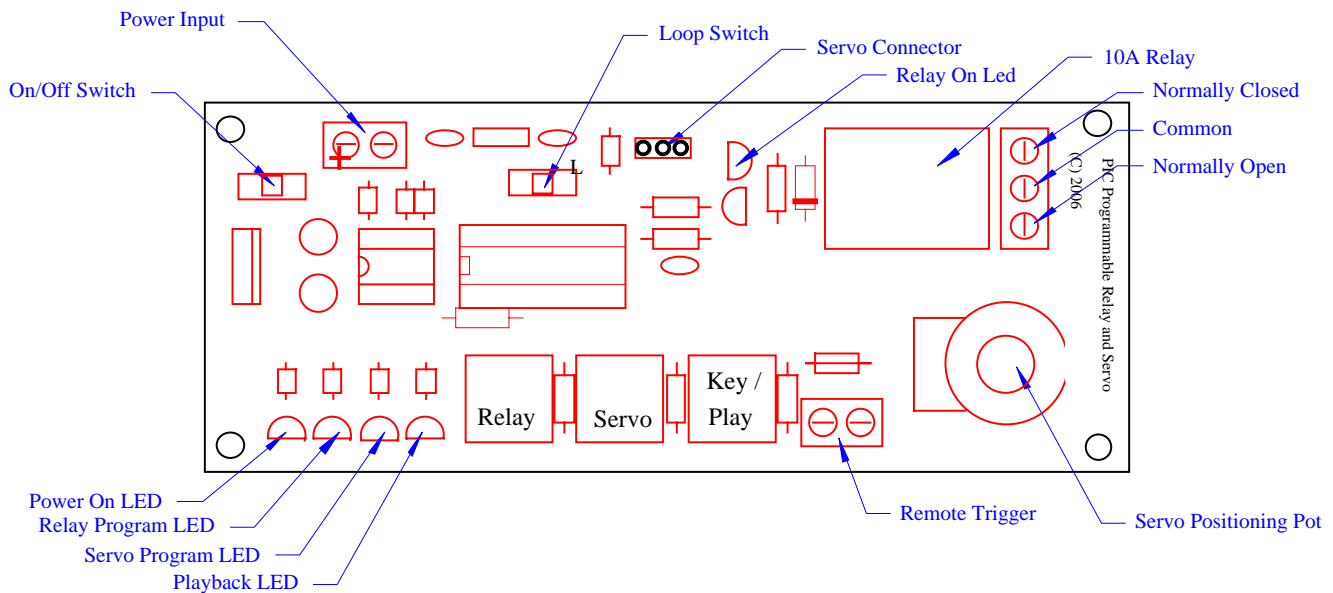

Specifications:

- Input Power: 7.5 – 24 VDC
- Current Draw: Less than 30 mA (while not powering servos)
- Relay Rating: 10A Max.
- Board Dimensions: 2.0 x 4.0 inches

Programmable Relay and Servo Board

Anytime you use a relay to control a solenoid valve, you need to suppress the kick back voltage to protect your relay board. We recommend using one of our suppression boards as shown in the diagram below.

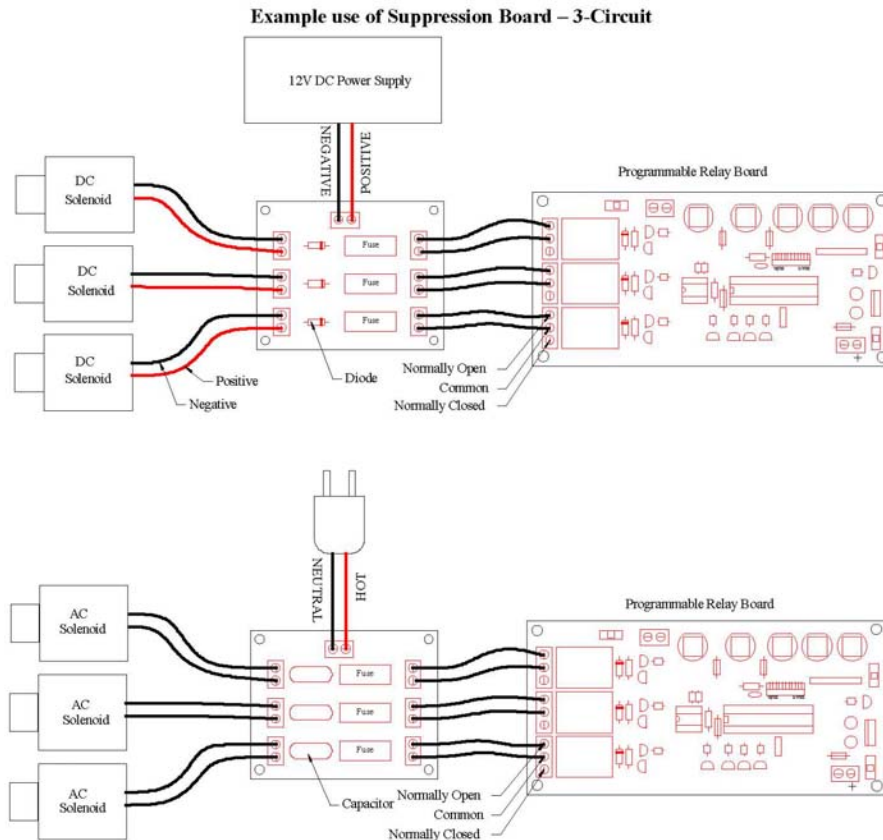

Disclaimer:

In no circumstances should these circuit boards be used in critical situations where failure could mean injury, death or property damage.

Please check out our other circuit board designs at www.evilsions.com

For more information, e-mail Brian at:

Gadget@evilsions.com