

EVILUSIONS

Programmable Relay Board – 3 Channel

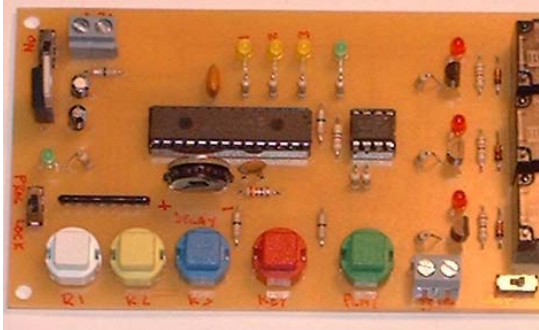

The Evilusions Programmable Relay Board allows you to program the on and off operation of three 10-amp rated on-board relays. The relays can be programmed to operate completely independent of each other and the program can last up to 8 minutes in length. The program, once entered, can be started by pressing a Play switch or connecting to a dry contact switch closure for remote triggering. There is also the ability to continually loop the program and there is an on-board potentiometer that will allow you to enter a delay between replays of up to 4 minute.

Details:

As mentioned above, the Evilusions Programmable Relay Board allows you to program the on and off operation of three 10-amp rated on-board relays. The relays can be programmed to operate completely independent of each other and programs can last up to 8 minutes in length. Other features include:

- A Loop feature that replays the program over and over
- A Delay Pot that allows you to enter a delay of up to 4 minute between program repeats while in Loop mode.
- Indicator lights showing which relay is being programmed.
- Relay actuates while program is being entered.
- Relays have indicator LEDs that show when relay is actuated.
- Ability to remotely trigger program
- Relays have normally open and normally closed contacts.
- Program remains in memory even with power removed.

Operation:

In order to program the board, you must switch the Program Lock Switch to PROG (see diagram below). When you are done programming the board, switch the switch back to LOCK and it will prevent you from accidentally initiating a programming sequence if you accidentally press one of the programming buttons. To program the first relay, momentarily press the first programming pushbutton. You will see a yellow LED light for that relay indicating that the program is being recorded. Press the Key pushbutton to actuate the relay. The relay on/off cycles can be of any number and length up to the 8 minute program time. When pressing the Key pushbutton, you will see the red LED associated with the relay light up when the relay is actuated as well as hear the relay click. When you are done recording that channel, press the programming pushbutton for that relay again and the yellow LED for that relay will go out. If you exceed the 8 minute time period, the board will automatically terminate the

Programmable Relay Board – 3 Channel

program and turn off the yellow LED. To program the second relay, press the second programming pushbutton. The second yellow LED will light indicating that the program is being recorded. This will also start the replay of the program sequence that was recorded for the first relay. This allows you to synchronize the second relay program to the first relay program. When done programming the second relay, press the second programming button again and the 2nd yellow LED will go out indicating that the storage of the program has stopped. If the length of the second program is shorter than the length of the first program, then the first relay program will continue to play until it finishes. The same scenario occurs when recording the third program – programs 1 and 2 will play while program 3 is being recorded. Once all three programs have been stored, you can play everything back by pressing the Play pushbutton – a green Play LED will light while the program is playing. Alternatively, you can hook a dry contact closure to the terminal block located next to the Play pushbutton and every time it is activated, the board will play back all 3 programs. If you want to continuously loop the stored programs, use the Loop Switch. In this mode, it will put in a delay of up to 4 minutes between replays which is entered via the on-board potentiometer. The maximum time delay is set by turning the Pot fully counter-clockwise (facing the board with the buttons closest to you). While in the delay period, the green Play LED will flash. When the program starts again, the Play LED will glow continuously.

You can re-record a program on any channel by simply repeating the programming process for that channel – it will overwrite whatever was previously recorded on that channel without affecting what was programmed on the other 2 channels. To completely erase a program for a channel, just press the programming pushbutton for that channel, let it record for a second or two (without pressing the Key pushbutton). Press the program button again to stop programming and the channel is now empty. Essentially, what you have done is record a 1-2 second program of nothing. Again, this has no effect on the programs stored in the other 2 channels.

The board requires a 12V DC power source (300 mA minimum). It is recommended that you use one power supply for the board and another to drive your devices.

Here is an example of how this can be used. Channel one is programmed to actuate a pneumatic cylinder which raises a ghoul head. Once the head is up, channel two can flash a light several times. Channel three can be used to actuate another device like an air cannon or you can use it to trigger our Digital Sound Recorder Board that will play back a loud monster's scream on a nearby speaker. If the ghoul's head is equipped with a servo to operate the mouth, attach our Sound to Servo Board to the Digital Sound Recorder Board and to the servo in the mouth and you now have quite a scary display – all from one trigger event!

Board Layout:

Below is a diagram showing component placement.

Programmable Relay Board – 3 Channel

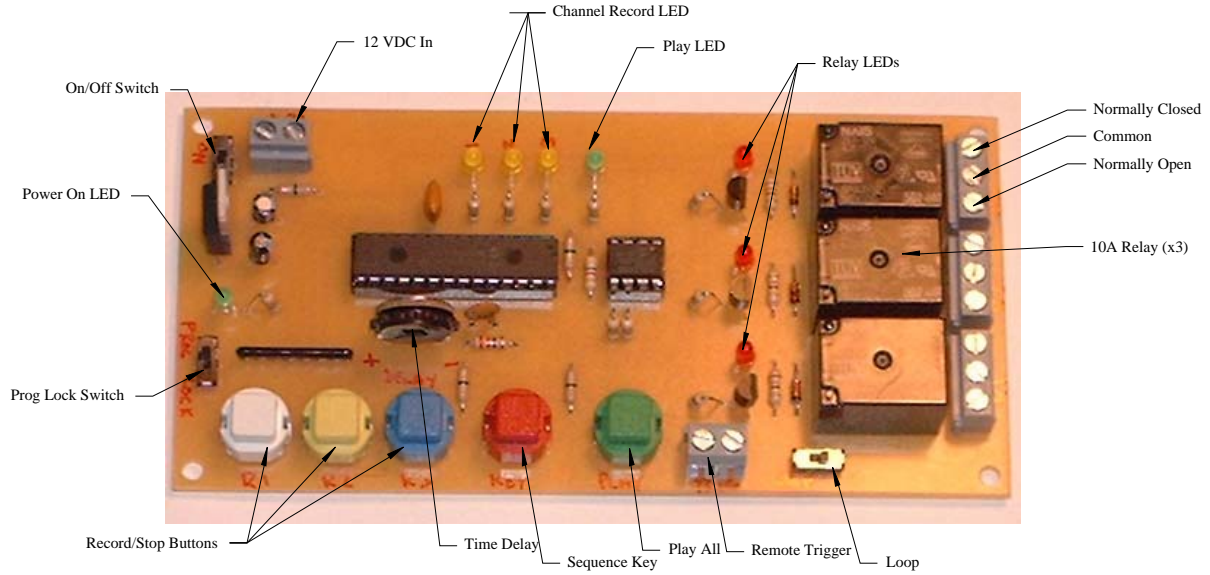

Specifications:

- Input Power: 12 VDC
- Current Draw: 300 mA (while not powering any other devices)
- Board Dimensions: 2.75 x 6.0 inches

Programmable Relay Board – 3 Channel

Anytime you use a relay to control a solenoid valve, you need to suppress the kick back voltage to protect your relay board. We recommend using one of our suppression boards as shown in the diagram below.

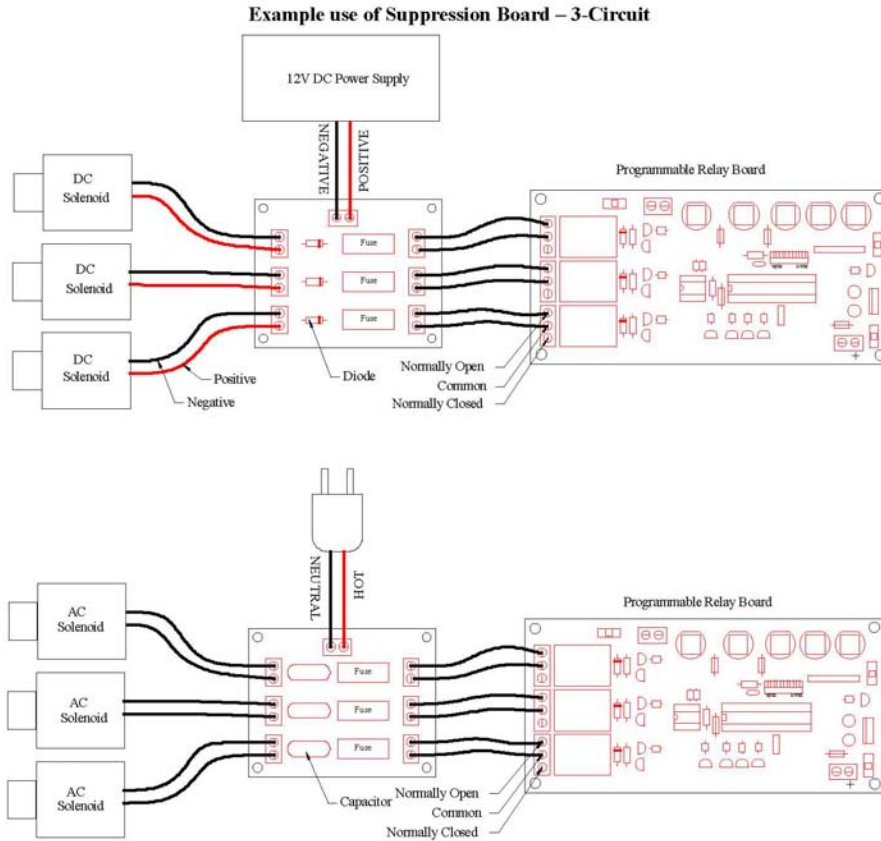

Disclaimer:

In no circumstances should these circuit boards be used in critical situations where failure could mean injury, death or property damage.

Please check out our other circuit board designs at www.evilsions.com

For more information, e-mail Brian at:

Gadget@evilsions.com